

Flameproof DC motors for hazardous locations

C Series – DC motors



Grandezze-Sizes 7 ÷ 23

[Catalogo – Catalogue](#)

General

Flameproof DC motors C Series had been expressly designed for a fully reliable operation and in conformity of safety prescriptions as requested by the regulation in force for electrical installations in dangerous environments.

The motors are certified by CESI (Centro Elettrotecnico Sperimentale Italiano) according to the Directive 94/9/CE (ATEX) for the following execution:

- Group : II (not mine)
- Category : 2 (high protection)
- Type of explosive atmosphere : G (gas, steams, smokes)
- Execution : EX d II B with class of temperature T3 for duty from S1 to S9
- Degree of protection : IP55 (according to IEC 34-5)

Motor design

Standards	:	IEC 60034
Supply	:	3-phase, 1-phase, batteries, Ward-Leonard group, chopper
Insulation	:	Class H
Temperature rise	:	Class H, F, B
Ambient temperature	:	-20°C - +40°C
		Minimum stocking temperature: -40°C
		Maximum working temperature (with derating): 60°C
Altitude of installation	:	1000masl max (up to 4000masl with derating)
Max. skin temperature	:	+200°C (class of di tempera ture T3)
Balancing	:	class G2,5 (ISO 2373)
Type of cooling	:	IC411 (IEC 34-6: self ventilated totally enclosed motor, frame externally cooled)
Degree of protection	:	IP55 (IEC 34-5)
Mounting	:	according to IEC 34-7
Main terminal box	:	at left side, viewed from DE

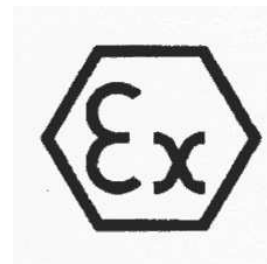
**Options available**

Thermoprotectors (NC contact)
 PTC thermal protector
 Pt100 thermistors
 Tachometer (explosion-proof type)
 Pulse generator (explosion-proof type)
 Anticondensation heater (excluding frame C7)
 Tropicalization of windings
 Brush wear control device (excluding frame 7)

**Bearings and lubrication data**

Frame size	Bearing type		Grease type	Bearing lubrication			
	Drive End	Non-Drive End		Grease q.ty (g)		Bearing re-greasing intervals (h)	
				DE	NDE	DE	NDE
C7/C7C	6204-2Z-C3	6203-2Z-C3	Lithium grade III	Greased for life	Greased for life	6500	7000
C11	6205-2Z-C3	6205-2Z-C3					
C13	6307-2Z-C3	6306-2Z-C3					
C16	6308-2Z-C3	6307-2Z-C3					
C19/C19H	6310-2Z-C3	6308-2Z-C3					
C23	NU313-C3	6310-2Z-C3					

CESI Certificates

Frame size	Execution + Class of Temperature	Motor Certificate No.	Extension Certificate
C 7	II 2G Exd IIB T3	CESI 03 – ATEX 322	01/08
C 7C	II 2G Exd IIC T3	CESI 03 – ATEX 322	01/08
C 11	II 2G Exd IIB T3	CESI 03 – ATEX 045	01/08
C 13	II 2G Exd IIB T3	CESI 03 – ATEX 045	01/08
C 16	II 2G Exd IIB T3	CESI 03 – ATEX 045	01/08
C 19	II 2G Exd IIB T3	CESI 03 – ATEX 306	02/08
C 19H	II 2G Exd IIB+H2 T3	CESI 03 – ATEX 306	02/08
C 23	II 2G Exd IIB T3	CESI 03 – ATEX 045	01/08

General prospectus for C Series motors according to ATEX Std (CEI EN 60079-0:2006/07 and CEI EN 60079-1:2005/11)

Group	II (not mines)							
Category	2 (high protection)							
Type of atmosphere	G (gas, steams, smokes)							
Motor type	C7	C7C	C11	C13	C16	C19	C19H	C23
Execution	Exd IIB	Exd IIC	Exd IIB	Exd IIB	Exd IIB	Exd IIB	Exd IIB+H ₂	Exd IIB
Class of surface temperature	T3		T3	T3	T3	T3		T3
Cooling type (IEC)	IC411		IC411	IC411	IC411	IC411		IC411
Cooling type (SICMEMOTORI code)	CvEd		CvEd	CvEd	CvEd	CvEd		CvEd
Degree of protection (IEC)	55		55	55	56	56		55
Minimum working temperature	-20 °C		-20 °C	-20 °C	-20 °C	-20 °C		-20 °C
Maximum working temperature	+60°C		+60°C	+60°C	+60°C	+60°C		+60°C
Maximum armature voltage	440V _{DC}		500V _{DC}	500V _{DC}	500V _{DC}	750 _{DC}		500V _{DC}
Maximum armature current (up to 40°C ambient temperature)	18A _{DC}		49A _{DC}	49A _{DC}	86A _{DC}	155A _{DC}		200A _{DC}
Maximum armature current (for 60°C ambient temperature)	15,5A _{DC}		43A _{DC}	43A _{DC}	76A _{DC}	135A _{DC}		175A _{DC}
Maximum motor power	1,2kW		2,4kW	6kW	14kW	25kW		35kW
Maximum motor speed	3600rpm		3000rpm	3000rpm	3600rpm	3200rpm		2500rpm
Temperature rise class	B or F		B or F	B or F	B or F	B or F		B or F
Nr. and max section of cables from armature to terminal board	6x2,5mm ²		6x25mm ²			6x50mm ²		
Terminal board installed into the terminal box	50x32 6 leds M4		70x45 6 leds M6			115x70 6 leds M10		
Terminal box entry cable	NPT ½		From NPT 1 to NPT 2			From NPT1 ½ to NPT 2 ½		
	From M16x1,5 to M33x1,5		From M20x1,5 to M50x1,5			From M25x1,5 to M75x1,5		
Auxiliary terminal box entry cable (for heaters, thermistors)	N/A		From NPT 1 to NPT 2			From NPT 1 ½ to NPT 2 ½		M25x1,5
			From M20x1,5 to M50x1,5			From M20x1,5 to M75x1,5		
Nr. and theoretical section supply cables into the terminal box	3x6mm ² + ground		3x35mm ² + ground			3x70mm ² + ground		

Anticondensation heaters

Frame size	Absorbed power
C7	N/A
C11	No. 1 x 42W
C13 up to C19	No. 2 x 42W
C23	No. 1 x 99W

Output data

Motor selection for Three-phase fully controlled bridge supply (by Single phase half controller bridge for (*))

Frame size	Speed (rpm)						
	1000	1200	1500	1800	2500	3000	3600
C 7 S *	0,1	0,12	0,16	0,2	0,3	0,35	0,42
C 7 M *	0,12	0,16	0,2	0,25	0,37	0,45	0,53
C 7 L *	0,16	0,2	0,25	0,3	0,47	0,6	0,64
C 11 S	0,56	0,72	0,9	1	1,5	1,75	2
C 11 M	0,72	0,9	1,1	1,25	1,9	2,2	2,5
C 11 L	0,9	1,1	1,3	1,5	2,4	2,8	3
C 13 S	1,5	1,9	2,2	2,8	4,2	4,8	5,5
C 13 M	1,9	2,2	2,8	3,4	5	5,8	6,7
C 13 L	2,3	2,7	3,4	4,2	5,8	7	7,8
C 16 S	3	3,5	4,2	5,2	7	8,7	9,5
C 16 M	3,5	4,5	5	6,2	8,5	10,5	11,5
C 16 L	4,3	5,5	6	7,3	10,5	12	
C 19 S / HS	5,6	6,6	8,4	9,8	14		
C 19 M / HM	6,7	8,3	10	12	16		
C 19 L / HL	8,3	10	12	14,5	18,5		
C 23 S	10	12	15,5	19	28		
C 23 M	12	15	20	23,5	33		
C 23 L	15	19,5	24,5	28,5	35		

Power in kW

Constant torque and/or constant power speed regulation

Constant torque speed regulation below nominal speed is possible in the ratio 1:2 (for duty S1).

This ratio can be increased up to 1:4 for application when load resistant torque is not constant when speed reduces (this is the case, for example, of centrifugal machines such as some pump and fan).

For higher ratio please ask SICMEMOTORI.

Constant power speed regulation above nominal speed (by reducing the field current at constant armature voltage) is possible up to 120% of nominal speed

For higher values please ask SICMEMOTORI



Output data

Motor selection for 110Vdc supply voltage by battery

Frame Size		rpm	Power output (kW) Vs. ambient temp.			Absorbed current at 40°C (A)	Nominal torque (Nm)	Efficiency at full load (%)
			at 40°C	at 45°C	at 50°C			
C 7L	C 7CL	1730	0,52	0,5	0,48	6,9	2,8	65
C 11S	N/A		1,15	1,1	1,06	12,9	6,2	78,2
C 11M			1,45	1,4	1,35	16	7,8	80
C 11L			1,8	1,75	1,7	19,2	9,8	83
C 13S		1,9	1,85	1,8	21,5	10	78,6	
C 13M		2,1	2,05	2	25,4	11	75	
C 13L		2,7	2,6	2,5	30	14,1	74	
C 16S		3,9	3,75	3,6	44,5	20,4	78	
C16M		5,2	5	4,9	58,2	27,3	80	
C16L		6,5	6,3	6,1	69	34,1	84	
C19S		C 19HS	1820	6,2	6	5,8	75	32,5
C19M	C 19HM	7,8		7,5	7,2	90,2	40,9	78
C 19L	C 19HL	8,8		8,5	8,2	101	46,1	78,2
C 23S	N/A	9,8		9,4	9,1	112	51,4	78,7
C 23M		13,2		12,7	12,3	144	69,3	82
C 23L		15,8		15,2	14,6	158	76,6	83

Motor selection for 125Vdc supply voltage by battery

Frame Size		rpm	Power output (kW) Vs. ambient temp.			Absorbed current at 40°C (A)	Nominal torque at 40°C (Nm)	Efficiency at full load at 40°C (%)
			at 40°C	at 45°C	at 50°C			
C 7L	C 7CL	1770	0,63	0,59	0,56	6,9	3,4	69
C 11S	N/A		1,25	1,2	1,15	12,8	6,9	75,7
C 11M			1,6	1,55	1,5	15,9	8,8	78,5
C 11L			2	1,95	1,9	19,2	11	82
C 13S		2,1	2,05	2	21,5	10,7	77	
C 13M		2,5	2,4	2,3	25,5	12,8	79,5	
C 13L		3,1	3	2,9	30	15,8	81	
C 16S		4,6	4,35	4,3	45	20,4	80	
C16M		6	5,9	5,8	58	30,6	82	
C16L		7,5	7,25	7	69	38,3	86	
C19S		C 19HS	1870	7,2	7	6,8	75	36,8
C19M	C 19HM	9,2		8,8	8,5	90	46,9	80
C 19L	C 19HL	10,3		9,9	9,6	101	52,6	80,6
C 23S	N/A	11,5		11,1	10,7	113	58,7	81,4
C 23M		15,5		14,9	14,4	144	79,2	85
C 23L		18,2		17,6	17	158	92,9	91

Notes: N/A: Not Available
Voltage acceptable tolerance +/-10%
Tolerance on speed as per EN60034-1
(\$): This motor is certified IIC

Direct starting

C Series DC motors are not suitable for direct starting.

In case of battery fed motors, a 2-steps starting resistance must be connected in series with the armature circuit, in order to reduce the starting current values within acceptable limits. The starting resistance must be connected during the motor starting operation only, and it must be disconnected once the starting occurred.

As an example, a scheme of motor starting with connecting-disconnecting 2-steps starting resistance is given below.

Values of starting resistances are given in the table below (general information)

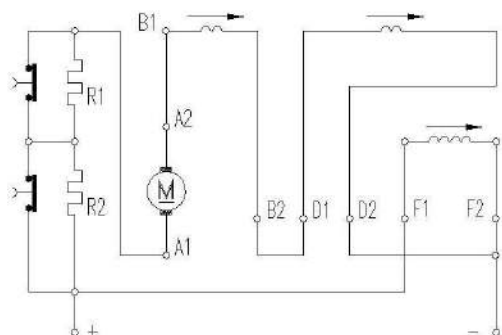

Clockwise direction of rotation

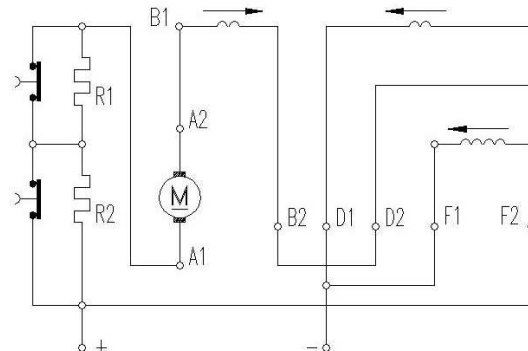

DC motor with compound excitation

Counter-clockwise direction of rotation

R1-R2 : starting resistances

A1-A2 : armature winding

B1-B2 : commutating winding (inside the motor)

F1-F2 : field winding

D1-D2 : stabilizing series

General information

Item	Frame size	Starting resistances (Ω)			Armat. Resist. (Ω)	Rotor PD ² (kgm ²)	Weight (kg)	Noise level at 1m (dBA)	Degree of protection	
		Amb. Temp.	110Vdc	125Vdc					ATEX IIB	ATEX IIB + H2 or IIC
1	C 7L C 7CL	50°C	2,5+2,5	3+3	2,5	0,015	55	80	IP55	IP55
		40°C	2,2+2,2	2,6+2,6						
2	C 11S	50°C	1,4+1,4	1,65+1,65	0,9	0,075	116	80	IP55	N/A
		40°C	1,25+1,25	1,5+1,5						
3	C 11M	50°C	1,2+1,2	1,4+1,4	0,54	0,085	122	80	IP55	N/A
		40°C	1,1+1,1	1,3+1,3						
4	C 11L	50°C	1,0+1,0	1,2+1,2	0,39	0,1	130	80	IP55	N/A
		40°C	0,95+0,95	1,1+1,1						
5	C 13S	50°C	0,96+0,96	1,1+1,1	0,237	0,21	170	80	IP55	N/A
		40°C	0,90+0,90	1,05+1,05						
6	C 13M	50°C	0,80+0,80	0,96+0,96	0,209	0,25	178	80	IP55	N/A
		40°C	0,76+0,76	0,87+0,87						
7	C 13L	50°C	0,70+0,70	0,8+0,8	0,15	0,3	188	80	IP55	N/A
		40°C	0,65+0,65	0,75+0,75						
8	C 16S	50°C	0,48+0,48	0,55+0,55	0,1	0,45	210	80	IP56	N/A
		40°C	0,45+0,45	0,5+0,5						
9	C 16M	50°C	0,37+0,37	0,42+0,42	0,059	0,5	230	80	IP56	N/A
		40°C	0,35+0,35	0,4+0,4						
10	C 16L	50°C	0,32+0,32	0,36+0,36	0,04	0,58	265	80	IP56	N/A
		40°C	0,30+0,30	0,34+0,34						
11	C 19S C 19HS	50°C	0,29+0,29	0,33+0,33	0,043	1	370	80	IP56	IP55
		40°C	0,27+0,27	0,31+0,31						
12	C 19M C19HM	50°C	0,24+0,24	0,28+0,28	0,03	1,1	395	80	IP56	IP55
		40°C	0,23+0,23	0,26+0,26						
13	C 19L C 19HL	50°C	0,22+0,22	0,25+0,25	0,02	1,3	420	80	IP56	IP55
		40°C	0,20+0,20	0,23+0,23						
14	C 23S	50°C	0,20+0,20	0,22+0,22	0,021	2,6	580	80	IP55	N/A
		40°C	0,18+0,18	0,21+0,21						
15	C 23M	50°C	0,16+0,16	0,18+0,18	0,013	2,9	635	80	IP55	N/A
		40°C	0,15+0,15	0,17+0,17						
16	C 23L	50°C	0,14+0,14	0,16+0,16	0,011	3,4	675	80	IP55	N/A
		40°C	0,13+0,13	0,15+0,15						

Note Tolerance +3 -0 dB(A)



SICMEMOTORI

Sicme Motori - Strada del Francese 130 - 10156 Torino - Italy
Tel. +390114076311 - Fax +390114500047 - www.sicmemotori.com - sicmemotori@sicmemotori.com

C-DC-ATEX-7-28-E-11

Dimensions – Foot mounted motor – Horizontal B3 (IM1001) or V5 (IM1011)

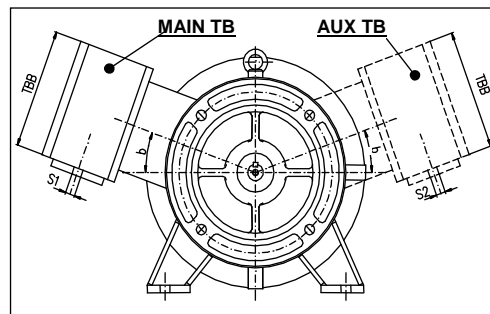
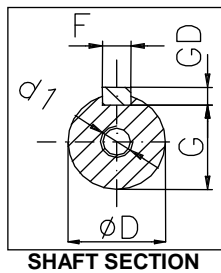
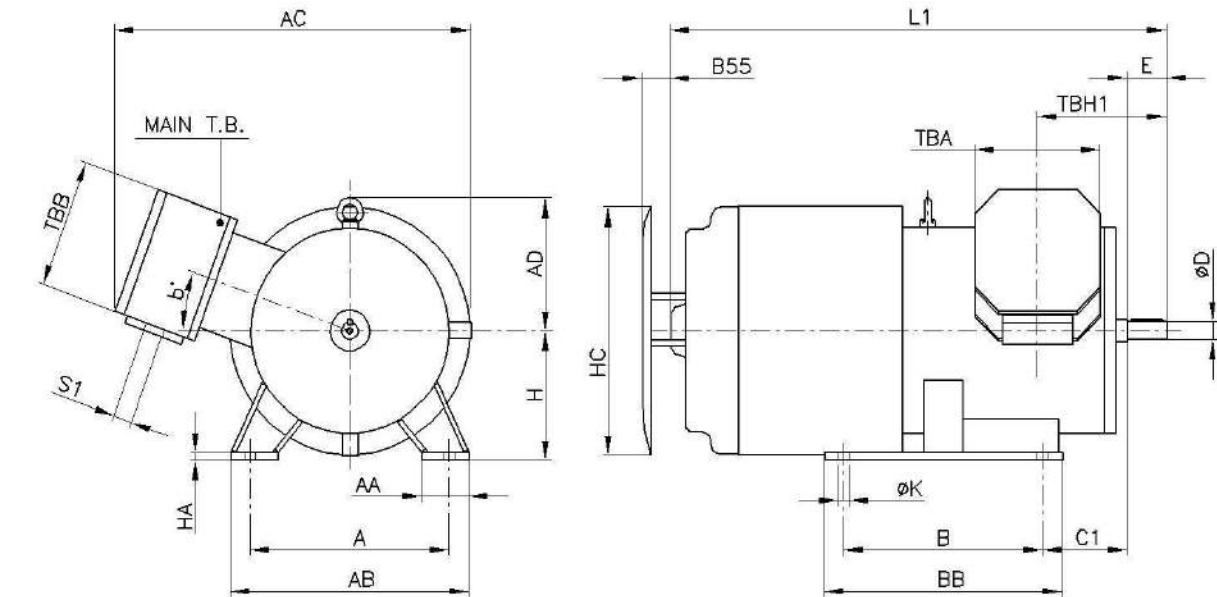

AUX TB POSITION FOR C11 to C19
(if requested by purchase order)

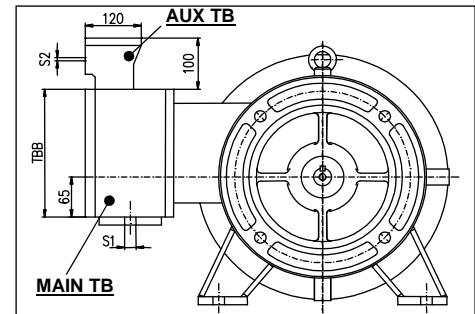

AUX TB POSITION FOR C23
(if requested by purchase order)

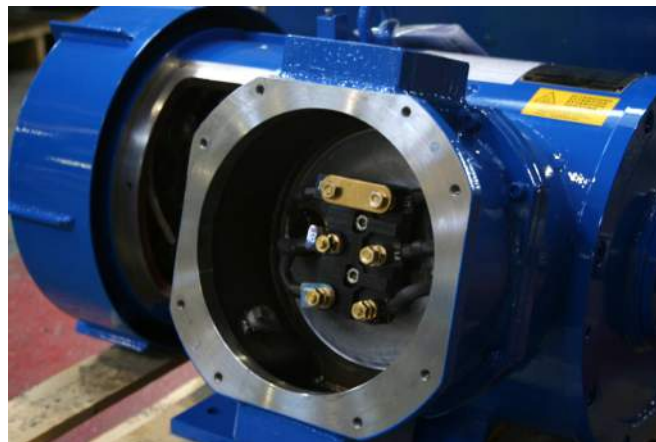

**Dimensions – Foot & flange mounted motor – Horizontal B34 (IM2101) or B35 (IM2001)
Vertical V15 (IM2011)**

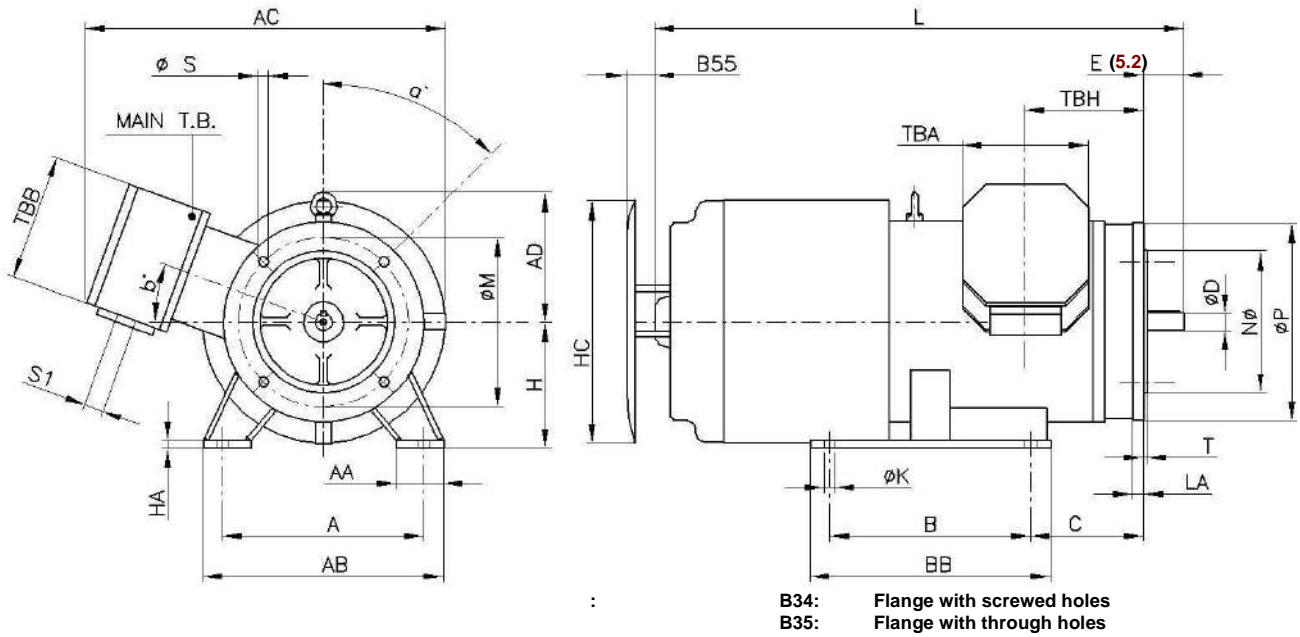

Dimensions – Flange mounted motor – Horizontal B5 (IM3101) or Vertical V1 (IM3001)

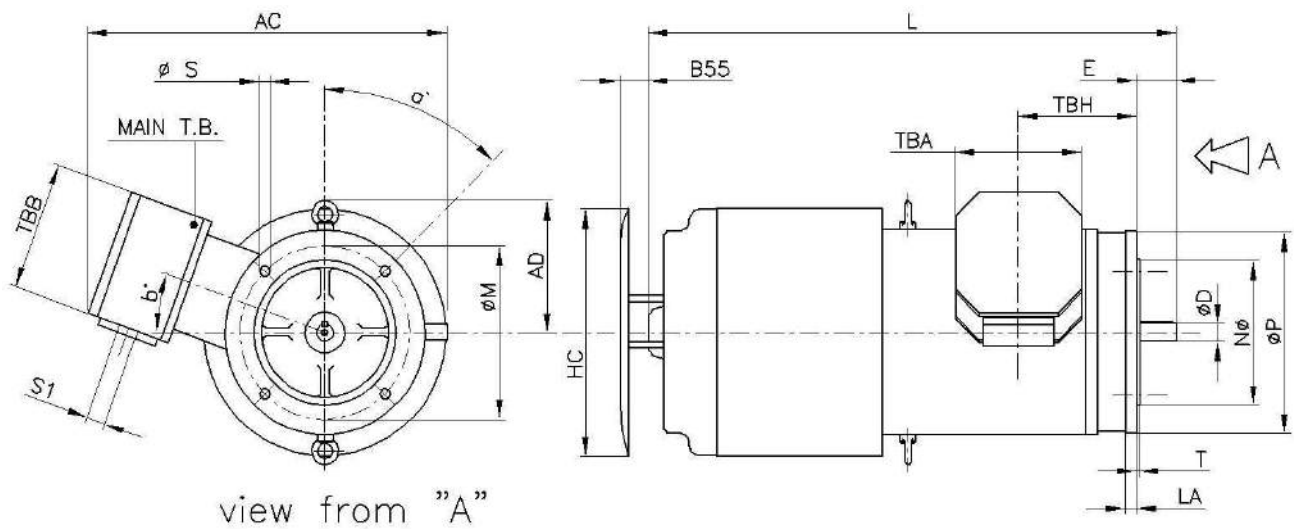

Main Dimensions

Motor type		Dimensions (mm)												
		A	AA	AB	AC	AD	B	BB	C	C1	H	HA	HC	Φ K
C7 / C7 C	L	165	57	241	347	122	140	175	74	N.A.	117	5	224	10
C 11	S	254	60	304	455	164	178	228	143	108	160	10	325	14
	M						210	260						
	L						254	304						
C 13	S	279	70	337	498	164	203	249	152	121	180	12	375	14
	M						241	287						
	L						279	325						
C 16	S	318	70	382	542	250	228	278	163	133	212	22	465	18
	M						267	317						
	L						305	355						
C19 / C19 H	S	356	90	446	685	243	286	346	176	149	225	18	485	18
	M						311	371						
	L						356	416						
C 23	S	457	120	545	722	273	368	440	190	190	280	22	580	22
	M						419	491						
	L						457	529						

Motor type		Dimensions (mm)											
		L	L1	S1 (6.1)		S2 (6.1)		Φ D	d1 (DIN332)	E	F (h9)	G	GD (h11)
				Tapered	Cyl-metric	Tapered	Cyl-metric						
C7 / C7 C	L	540	540	NPT 1 1/2"	20x1,5	N/A	N/A	19,05 j6	M6X16	62	4,57	16,43	4,57
C11	S	620	580	NPT 2"	63x1,5	NPT 2"	M20x1,5	22 j6	M8X19	50	6	18,5	6
	M	645	605										
	L	675	635										
C13	S	721	685	NPT 2"	63x1,5	NPT 2"	M20x1,5	28 j6	M10X22	60	8	24	7
	M	751	715										
	L	786	750										
C16	S	810	775	NPT 2"	63x1,5	NPT 2"	M20x1,5	32 k6	M12X28	80	10	27	8
	M	845	810										
	L	885	850										
C19 / C19 H	S	872	840	NPT 2 1/2"	75x1,5	NPT 2 1/2"	M25x1,5	48 k6	M16X36	110	14	42,5	9
	M	912	880										
	L	957	925										
C23	S	1145	1145	NPT 2 1/2"	75x1,5	NPT 2 1/2"	M25x1,5	60 m6	M20X42	140	18	53	11
	M	1190	1190										
	L	1245	1245										

Note (6.1) Tapered / Cyl.-Metric

Flange & Terminal Box Dimensions

Motor type	FF flange dimensions (mm)									B55	TBH	TBA	TBB	TBH1	b
	Fl. Size	LA	Φ M	Φ N	Φ P	T	Φ S	A	Holes Nr						
C7 / C7 C	N.A.	15	149	114,31 j6	172	3	3/8" UNC	45°	8	-	132	140	140	132	22,5°
C 11	FF-215	14	215	180 j6	250	4	14	45°	4	50	150	160	160	115	20°
C 13	FF-265	14	265	230 j6	300	4	14	45°	4	52	142	160	160	111	15°
C 16	FF-300	15	300	250 j6	350	5	19	45°	4	58	138	160	160	108	20°
C 19 / C19 H	FF-300	13	300	250 j6	350	5	19	45°	4	55	188	260	260	161	15°
C 23	FF-500	22	500	450 j6	550	5	19	22,5°	8	73	246	260	260	246	-

ATEX 94/9/EC Directive (offprint)

The ATEX Directive 94/9/EC applies to all mechanical and electrical products used in areas, with both gas and dusty ambience, with a potential risk of explosion.

The Directive provides for the issuance of dual certificate:

- The conformity of the prototype
- The conformity of production (evaluation of the quality management system).

The ATEX marking is COMPULSORY for all products that will be installed in potentially explosive areas within countries belonging to the European Union

Warnings for the plant engineer

Given the complexity and importance of the matter, it is suggested that plant engineer which have to tackle a project that includes places at risk of explosion or fire refer to CEI 64-2 ed. VII, 1973, file 319 and IEC 79-10 "Standards for systems in places with danger of explosion or fire."

In general, the plant engineer has to decide what is the real risk of explosion or fire in the area and which materials contribute to constitute a risk of explosion. The risk areas are areas where under certain conditions explosive atmosphere may develop

The ATEX Directive 94/9/EC defines an explosive atmosphere as a mixture of:

1. flammable substances in the form of gases, vapors, mists (and dust);
2. with air;
3. in certain atmospheric conditions;
4. in which, after ignition, combustion spreads to the entire unburned mixture (not always, however, in the presence of dust, the entire quantity of dust is consumed by combustion).

An atmosphere which could become explosive due to local conditions is defined as potentially explosive atmosphere, and it is only this kind of atmosphere that is intended for products covered by the ATEX Directive 94/9/EC. When one or more of the above elements is not present, the atmosphere is no longer considered to be potentially explosive. The local authorities (fire departments, the National Inspectorate) are the competent bodies to be approached for approval of a classification of a potentially explosive area.

Warnings for the user

The Flameproof explosion-proof DC machines must be serviced regularly as per the. operating and maintenance manual supplied by SICMEMOTORI.

In addition, we must not forget that these machines must be able to work safely in areas at risk of explosion or fire, even after being subjected to any maintenance operation.

It is therefore indispensable to be aware that if any machine is in any way altered without the prior written permission of SICMEMOTORI, it can loose the characteristics that make it suitable for installation in hazardous environments and for which it was designed, built and certified . In this case, it can no longer be classified as explosion-proof and all the symbols of identification (Exd, IIB, T3, etc..) must be removed.

Repairs

Repairs of explosion-proof motors must be conducted according to criteria specified by IEC 79-19 Standards.

If repairs are not made by SICMEMOTORI, they must be carried out in workshops which have the necessary equipment for repairs and technical knowledge relating to methods of protection of motors.

In case of repairs on parts that influence the protection against the risk of explosion, manufacturing motors data must not be modified (for example: size of the joints, characteristic of the windings, etc.) and the repaired parts must be tested .

A written declaration must be done with the description of the actions taken.

In case of repairs that modify aspects relevant to Ex protection (see for example what earlier specified about explosion-proof joints) and the motor after the repair is no longer comply with the certificate, the original motor name plate must be removed and the motor can no longer be considered suitable for use in areas with danger of explosion. For further use in these areas, the motor must be re-examined by a competent certification body.



CERTIFICATE

IQNet and its partner
CISQ/IMQ-CSQ
herby certify that the organization
SICME MOTORI SRL
STRADA DEL FRANCESE 123-126-130 - 10156 TORINO (TO)

for the following field of activities
Design, engineering, production and sale of direct current motors and generators: alternate current, permanent magnets synchronous, reluctance
Refer to quality manual for details of applications to ISO 9001:2000 requirements
has implemented and maintains a
Quality Management System
which fulfills the requirements of the following standard

ISO 9001:2000
Issued on: 2008 - 10 - 31

Registration Number: **IT - 1088**

IQNET
René Wismer
President of IQNET

CISQ
Gianvencio Prati
President of CISQ

IQNet partners*:
AENOR Spain, AFAQ AFNOR France, AIB-Vinotte International Belgium, ANCE Mexico, APCER Portugal, CISQ Italy, CQC China, CQM China, CQS Czech Republic, Cro Cert Croatia, DQS Germany, DS Denmark, ELOT Greece, FCAV Brazil, FONDONORMA Honduras, HKQAA Hong Kong China, ICONTEC Colombia, IMNC Mexico, Inspira Certification Finland, IRAM Argentina, IQA Japan, KFQ Korea, MSZT Hungary, Niemo AS Norway, NSAI Ireland, PCB-C Poland, QMI Canada, Quality Assuris Australia, RQ Russia, SAI Global Australia, SII Israel, SIQ Slovenia, SIRIM QAS International Malaysia, SQS Switzerland, SRAC Romania, TEST St Petersburg Russia, YUQS Serbia
IQNet is represented in the USA by: AFAQ AFNOR, AIB-Vinotte International, CISQ, DOS, NSAI Inc., QMI and SAI Global.
*The list of IQNet partners is valid at the time of issue of this certificate. Updated information is available under www.iqnet-certification.com



CERTIFICATO N. **9101.SMOT**
CERTIFICATE N. **9101.SMOT**

SI CERTIFICA CHE IL SISTEMA QUALITA' DI
WE HEREBY CERTIFY THAT THE QUALITY SYSTEM OPERATED BY
SICME MOTORI SRL
STRADA DEL FRANCESE 130 - 10156 TORINO (TO)
UNITA' OPERATIVE
OPERATIVE UNITS
STRADA DEL FRANCESE 123-126-130 - 10156 TORINO (TO)
E' CONFORME ALLA NORMA
IS IN COMPLIANCE WITH THE STANDARD

ISO 9001:2000

PER LE SEGUENTI ATTIVITA'
FOR THE FOLLOWING ACTIVITIES
Progettazione, produzione e vendita di motori e generatori elettrici: a corrente continua, corrente alternata, sincroni a magneti permanenti, a riluttanza
Design, engineering, production and sale of direct current motors and generators: alternate current, permanent magnets synchronous, reluctance
Riferirsi al manuale della qualità per l'applicabilità dei requisiti della norma ISO 9001:2000
Refer to quality manual for details of applications to ISO 9001:2000 requirements

IL PRESENTE CERTIFICATO E' SOGGETTO AL RISPETTO DEL REGOLAMENTO
PER LA CERTIFICAZIONE DEI SISTEMI DI QUALITA' E DI GESTIONE DELLE AZIENDE
THE USE AND THE VALIDITY OF THE CERTIFICATE SHALL SATISFY THE REQUIREMENTS
OF THE RULES FOR THE CERTIFICATION OF COMPANY QUALITY AND MANAGEMENT SYSTEM

PRIMA EMISSIONE FIRST ISSUE	EMISSIONE CORRENTE CURRENT ISSUE	DATA SCADENZA EXPIRY DATE
1991-05-16	2008-10-31	2011-07-30

[Signature]
IMQ S.p.A. - VIA QUINTILIANO, 43 - 20138 MILANO ITALY



IQNet, the association of the world's first class certification bodies, is the largest provider of management system certification in the world. Active in more than 80 countries and across over 150 industries, all over the globe.

CISQ is the Italian Federation of management system certification bodies



CESI

CERTIFICATE

CESI Centro Elettrotecnico Sportivissimo Italiano
Via R. Rubattino 54
00144 Milano - Italia
Tel: +39 02 70712540
Fax: +39 02 70712540
www.cesi.it

Schema di certificazione **CESI-ATEX**

- EC-TYPE EXAMINATION CERTIFICATE**
- Equipment or Protective System intended for use in potentially explosive atmospheres Directive 94/9/EC
 - EC-Type Examination Certificate number:
CESI 03 ATEX 045
 - Equipment: d.c. motors types C11, C13, C16 and C23.
 - Manufacturer: **SICMEMOTORI S.p.A.**
 - Address: Strada del Francese 126-130, 10156 Torino (Italy)
 - This equipment or protective system and any acceptable variation thereto is specified in the schedule to this certificate and the documents therein referred to.
 - CESI, notified body n. 0722 in accordance with Article 9 of the Council Directive 94/9/EC of 23 March 1994, certifies that this equipment or protective system has been found to comply with the Essential Health and Safety Requirements relating to the design and construction of equipment and protective systems intended for use in potentially explosive atmospheres given in Annex II to the Directive.
The examination and test results are recorded in confidential report n. EX-A3/007874.
 - Compliance with the Essential Health and Safety Requirements has been assured by compliance with:
EN 50014:1997 + A1-A2 EN 50018:2000 + A1
 - If the sign "X" is placed after the certificate number, it indicates that the equipment or protective system is subject to special conditions for safe use specified in the schedule to this certificate.
 - This EC-TYPE EXAMINATION CERTIFICATE relates only to the design, examination and tests of the specified equipment or protective system in accordance to the Directive 94/9/EC. Further requirements of the Directive apply to the manufacturing process and supply of this equipment or protective system. These are not covered by this certificate.
 - The marking of the equipment or protective system shall include the following:
 II 2 G EEx d IIB T3

This certificate may only be reproduced in its entirety and without any change, schedule included.
Date June 25th 2003 translation issued on June 25th 2003

Prepared *Mirko Balaz*
Approved *Ulisse Colombo*
CESI
CENTRO ELETTROTECNICO SPORTIVISSIMO ITALIANO
Business Unit Certification
Via R. Rubattino 54
00144 Milano - Italia
Tel: +39 02 70712540
Fax: +39 02 70712540
www.cesi.it

CESI

NOTIFICATION

CESI Centro Elettrotecnico Sportivissimo Italiano
Via R. Rubattino 54
00144 Milano - Italia
Tel: +39 02 70712540
Fax: +39 02 70712540
www.cesi.it

Schema di certificazione **CESI-ATEX**

- PRODUCT QUALITY ASSURANCE NOTIFICATION**
- Equipment or Protective System or Component intended for use in potentially explosive atmospheres Directive 94/9/EC
 - Notification number:
CESI 03 ATEX 309 Q
 - Equipment or component type: Direct current electric motors
Protection concepts: Flameproof enclosures "d"
 - Applicant: Sicme Motori S.p.a.
Strada del Francese, 126-130
10156 Torino - TO
 - Manufacturer: Sicme Motori S.p.a.
Strada del Francese, 126-130
10156 Torino - TO
 - CESI, notified body n. 0722 in accordance with Article 9 of the Council Directive 94/9/EC of 23 March 1994, notifies to the applicant that the actual manufacturer has a product quality system which complies to Annex VII of the Directive.
 - This notification is based on audit report n. EX-A7014521.
This notification can be withdrawn if the manufacturer no longer satisfies the requirement of Annex VII.
Results of periodical re-assessment of the quality system are a part of this notification.
 - This notification is valid until 11/2/2009 and can be withdrawn if the Manufacturer does not satisfy the product quality assurance re-assessment.
 - According to Article 10 [1] of the Directive 94/9/EC the CE marking shall be followed by the identification n. 0722 identifying the notified body involved in the production control stage.
This notification may only be reproduced in its entirety and without any change.

Date of 1st issue **1st December 2003** Date of renewal **1st December 2006**
Translation issued the **1st December 2006**

Prepared *Sergio Grugno*
Verified *Mirko Balaz*
Approved *Firenze Breganti*
CESI
Centro Elettrotecnico Sportivissimo Italiano
Via R. Rubattino 54
00144 Milano - Italia
Tel: +39 02 70712540
Fax: +39 02 70712540
www.cesi.it

Examples of certificates



Sicme Motori - Strada del Francese 130 - 10156 Torino - Italy
Tel. +390114076311 - Fax +390114500047 - www.sicmemotori.com - sicmemotori@sicmemotori.com

C-DC-ATEX-7-28-E-11

Some word about SICMEMOTORI

SICMEMOTORI has been designing, manufacturing and selling DC motors since 1962, at first as a Division of SICME (producing wire enamelling plants) and then, from 1967, as an independent company; from the beginning its products have been well received because of their quality and reliability.

SICMEMOTORI products have followed the complete evolution of DC motors technology, and today SICMEMOTORI is one of the leading manufacturers of DC motors in Europe. More than 85% of SICMEMOTORI DC motors are directly or indirectly exported.

The Company is located in Turin, in the North-West part of Italy, in one of the most industrialized area of Europe. The Company is organized on the principles of "lean production" and "learning organization". The integrated IT system of the Company controls all its activities, from order entry to the delivery of materials. Production is managed by a modern "MRP" system, and all operations are controlled by bar code; production is carried out in two plants, with a total surface area of approximately 10,500 sqm. Customers are allowed, via a password, to enter the company's IT system, to check status of their own orders.

Motors are produced according to ISO 9001 quality assurance system.

Due to its long history, SICMEMOTORI has achieved a very high level of experience in the most severe applications, from iron & steel mills to rubber mixers (Banburies), from cranes & hoists to chairlifts & funiculars, to cement factories, mining industries, paper & print machines, sugar centrifuges, plastic extruders and film process, etc..

SICMEMOTORI products can be found all over the world; the after sales service is provided by a network of authorized repair shops, selected and certified by SICMEMOTORI (the updated list is on SICMEMOTORI web site www.sicmemotori.com). SICMEMOTORI is member of EASA.

Notes:

Customers can determine whether a specific product is suitable for their needs and are thus responsible for the selection, use and results obtained by any product showed in this catalogue. The information contained in the present catalogue does not guarantee the characteristics for the use.

The products listed in this catalogue are exclusively designed and built for industrial purposes.

For particular cases in NON-industrial environments, or where other types of protection must be provided (for example against contact with children fingers, etc.), these guards or additional protections must be realized by the customer.

Any non-observance of the rules for installation, use and maintenance or any modification/tampering with the motor makes the guarantee rights invalid and exempts SICMEMOTORI from any responsibility.

All data and indications shown in this catalogue have to be considered only as a guideline.

Any use of the motor differently from the specifications indicated in this catalogue does not involve any liability for SICMEMOTORI as manufacturer.

SICMEMOTORI reserves the right to modify at any time and without notice the data, the technical characteristics, the dimensions, the weights and the illustrations.

SICMEMOTORI refuses all responsibility for direct or indirect damages caused by possible errors and/or omissions in the present catalogue.

The reproduction, even in part, of the present catalogue must be authorized in writing by SICMEMOTORI.



WARNING

The motors and the electrical devices feeding them are electrical components installed on machines and industrial systems subject to high voltage. During operation, these components can be dangerous since they are live and have non-insulated and rotating parts. Therefore, they can be extremely harmful to personnel and objects if the instructions for the installation, the use and the maintenance are not respected.

The motors are always supplied complete with the installation, use and maintenance instruction manual. It is necessary to read and understand all the information contained before proceeding to connect and to start up the installation.

If the above mentioned documentation is lacking, please request a copy to SICMEMOTORI.

CAUTION

All information, data, drawings given in this catalogue are of a purely indicative nature and may be changed without prior notice. SICMEMOTORI shall not be held responsible if the products illustrated herein are used outside their limits of the specifications given.

