

IPH

# High-Pressure Internal Gear Pumps Technical Data Sheet

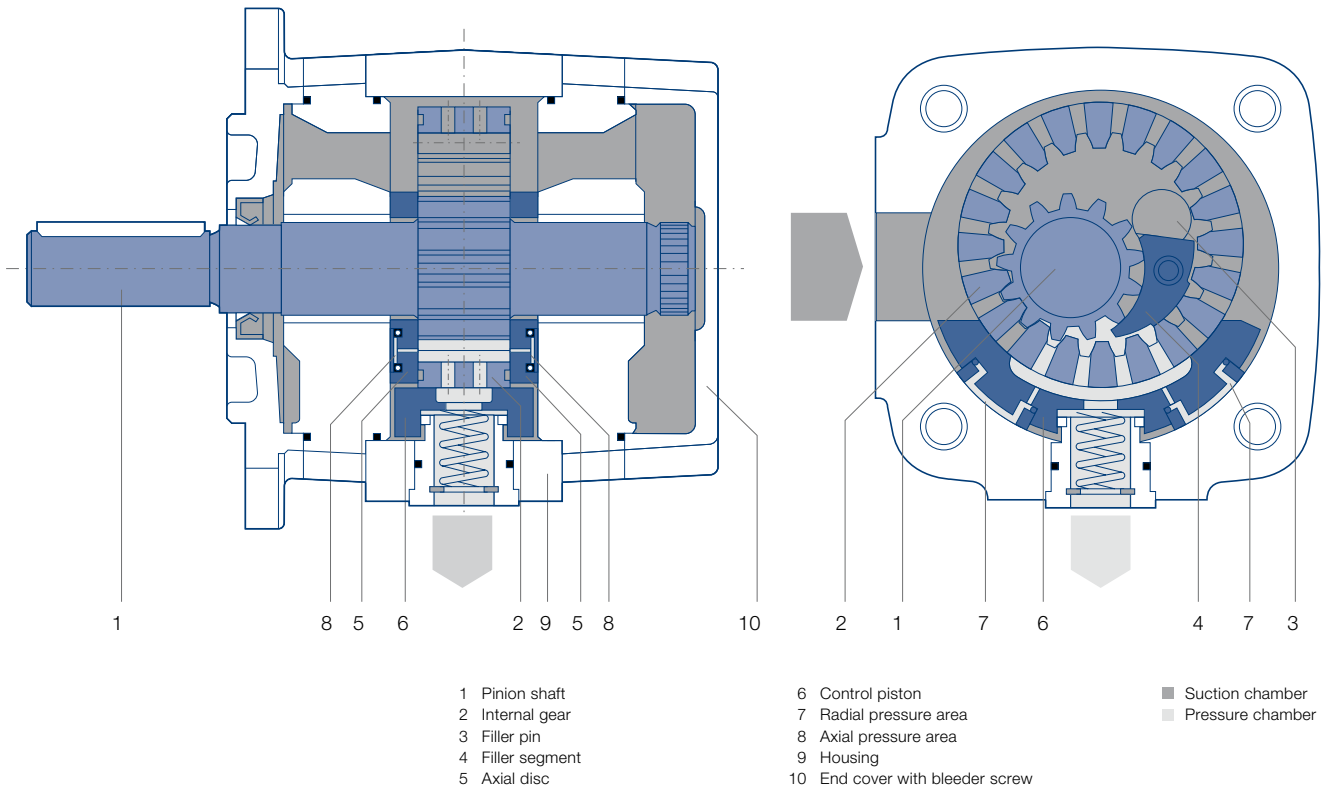

## Design and Function



### Function

Rotation of the gears within the pump draws in the pressure fluid (usually hydraulic oil) into the space between the pinion and internal gear. The two smooth running gears help to ensure excellent intake behavior.

In the radial direction, the gear chambers are sealed by gear meshing and the filler piece. In the axial direction, the axial

plates seal the pressure chamber with the minimal possible gap. This design minimizes volume losses and increases efficiency. When the gears rotate, the pinion teeth enter the gaps between the internal gear teeth and displace the pressure fluid.

### Calculations

Delivery	$Q = V_{g,th} \cdot n \cdot \eta_v \cdot 10^{-3} \text{ [l/min]}$
Power	$P = \frac{Q \cdot \Delta p}{600 \cdot \eta_g} \text{ [kW]}$
$V_{g,th}$	Pump volume per revolution [cm <sup>3</sup> ]
$n$	Speed [min <sup>-1</sup> ]
$\eta_v$	Volumetric efficiency
$\eta_g$	Overall efficiency
$\Delta p$	Differential pressure [bar]

## Technical data

Design	Internal gear pump with radial and axial sealing gap compensation
Type	IPH
Mounting types	SAE-hole flange; ISO 3019/1
Line mounting	SAE-suction and pressure flange J 518 C Code 61
Rotation direction	clockwise or counterclockwise
Mounting position	any
Shaft load	For details of radial and axial drive shaft loads, please contact your Voith representative
Input pressure	0.8 ... 3 bar absolute pressure (at start briefly 0.6 ... 3 bar)
Pressure fluid	HLP mineral oils DIN 51524, part 2 or 3
Viscosity range of the pressure fluid	10 ... 300 mm <sup>2</sup> s <sup>-1</sup> (cSt)
Permissible start viscosity	Max. 2 000 mm <sup>2</sup> s <sup>-1</sup> (cSt)
Permissible temperature of the pressure fluid	-20 ... +80 °C
Necessary purity of the pressure fluid in accordance with NAS 1638	Class 8
Filtration	Filtration quotient min. $\beta_{20} \geq 75$ , recommended $\beta_{10} \geq 100$ (longer service life)
Permissible ambient temperature	-10 ... +60 °C

## Characteristics

Type, size-delivery	Displacement per revolution [cm <sup>3</sup> ]	Speed		Delivery	Pressures within the range $n_{\min} \dots n_{\max}$	
		min. [min <sup>-1</sup> ]	max. [min <sup>-1</sup> ]	at 1500 min <sup>-1</sup> [l / min]	Continuous pressure [bar]	Peak pressure [bar]
IPH 4 – 20	20.7	300	3 000	31.0	300	330
IPH 4 – 25	25.7	300	3 000	38.6	250	315
IPH 4 – 32	32.3	300	3 000	48.5	250	300
IPH 5 – 40	40.8	300	3 000	61.2	300	330
IPH 5 – 50	50.3	300	3 000	75.4	250	315
IPH 5 – 64	63.9	300	3 000	95.8	250	300
IPH 6 – 80	81.3	300	2 500	121.9	300	330
IPH 6 – 100	101.6	300	2 500	152.4	250	315
IPH 6 – 125	125.6	300	2 500	188.8	250	300

### The values given apply for:

- Pumping of mineral oils with a viscosity of 20...40 mm<sup>2</sup>s<sup>-1</sup>
- An input pressure of 0.8...3.0 bar absolute

### Notes:

- Peak pressures apply for 15% of operating time and a maximum cycle time of 1 minute
- Please enquire about pressures lower than  $n_{\min}$
- Due to production tolerances, the pump volume may be approx. 1.5 % lower

## IPH Standard design 4, Rotation and Dimensions

Clockwise rotation (cw)

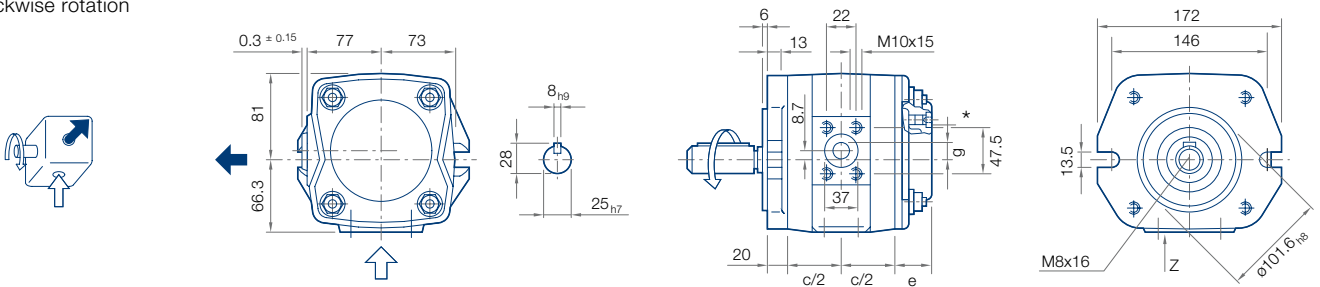

Counterclockwise rotation (ccw)

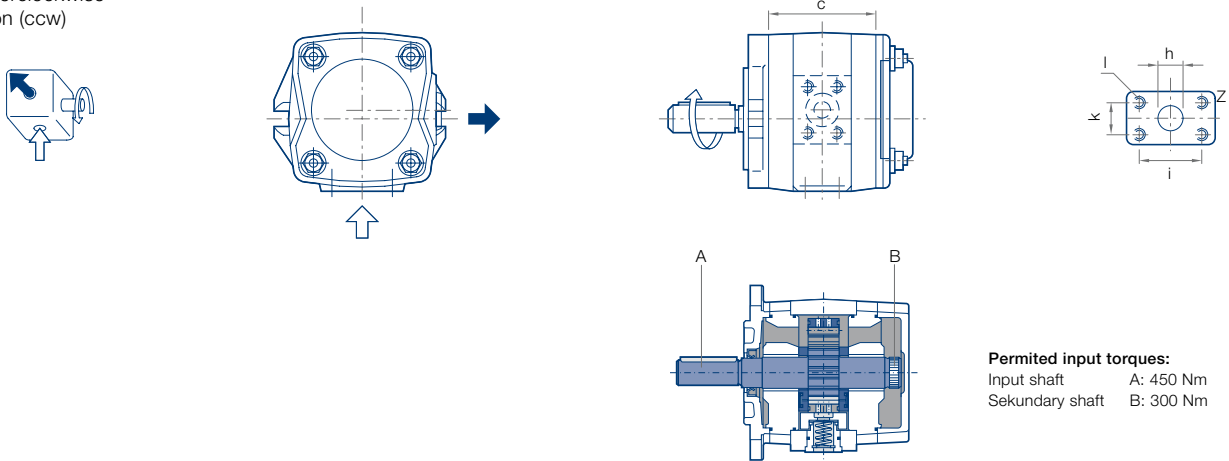

Type / Delivery	Dimensions and Weight								SAE-Flange-No.	
	c	e	g	h	i	k	l	m	↑	↓
	[mm]	[mm]	[mm]	[mm]	[mm]	[mm]	Thread	[kg]		
IPH 4 – 20	102	36	19	30	58.7	30.2	M10 x 15	13.5	11	13
IPH 4 – 25	108	36	21	30	58.7	30.2	M10 x 15	14.2	11	13
IPH 4 – 32	116	36	24	32	58.7	30.2	M10 x 15	15.0	11	13

\* The plug screw must be closed during operation. Ensure the M10x1 plug screw, hexagon socket SW5, is tightened to a torque of 10 Nm. Depending on the pump position, filling or ventilation is possible with the M10x1 plug screw prior to commissioning.

### Delivery Q

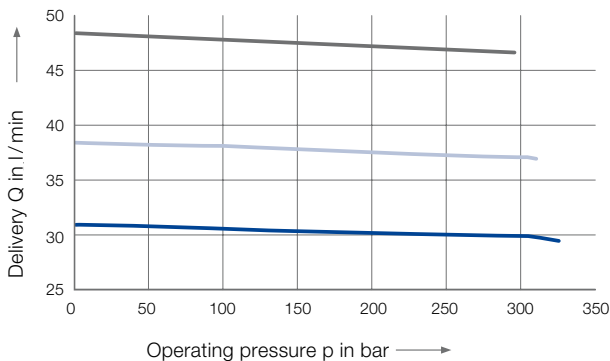

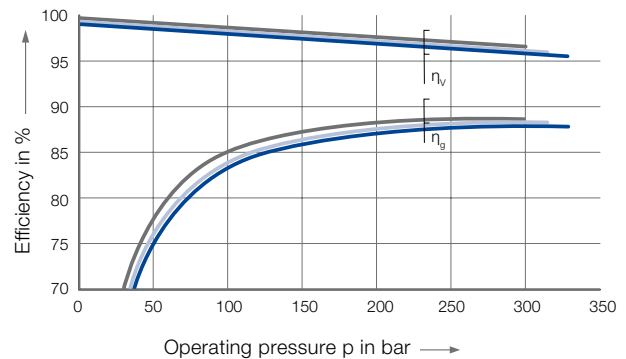

**Note:**  
Measurement taken in a low-noise room.  
In an anechoic room, the measurements are approx. 5 dB(A) lower.

### Efficiency $\eta_v$ and $\eta_g$

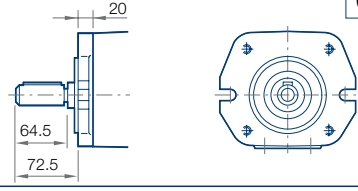
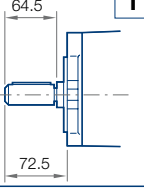

**Measurement conditions:**  
Speed: 1500 min<sup>-1</sup> / Viscosity of pressure fluid: 46 mm<sup>2</sup>s<sup>-1</sup> /  
Operating temperature: 40 °C

IPH standard design 4, Designs

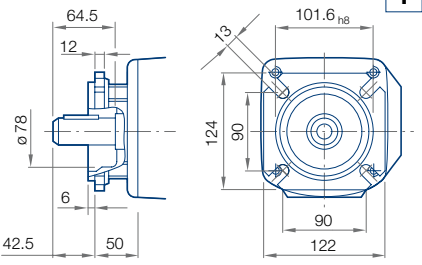
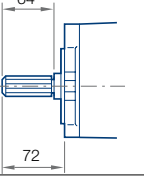
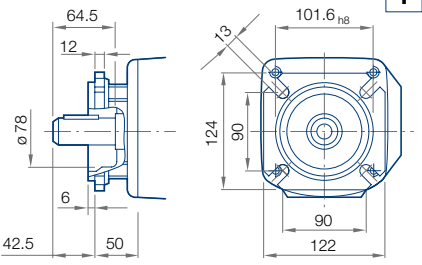
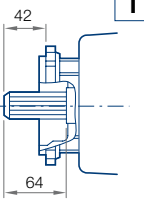
Type	Pump sizes	Rotation, suction connection	Mounting flange	Shaft end
IPH 4	20 25 32	Standard		
		Clockwise rotation, radial suction port <b>1</b> 	SAE-2-hole-flange, dimensions on left <b>0</b> 	Parallel shaft with keyway connection, dimensions on left <b>1</b> 
		Variants		
		Counterclockwise rotation, radial suction port <b>6</b> 	SAE-4-hole-flange <b>1</b> 	Involute gearing with SAE-2-hole-flange <b>0</b> ANSI B92.1a 13T 16/32 DP 30° 
			SAE-4-hole-flange <b>1</b> 	Involute gearing with SAE-4-hole-flange <b>1</b> ANSI B92.1a 13T 16/32 DP 30° 

Designation according to type code  
 Type code/order designation, see page 13

Input power P

Airborne noise level (Measurement site 1 m axial)

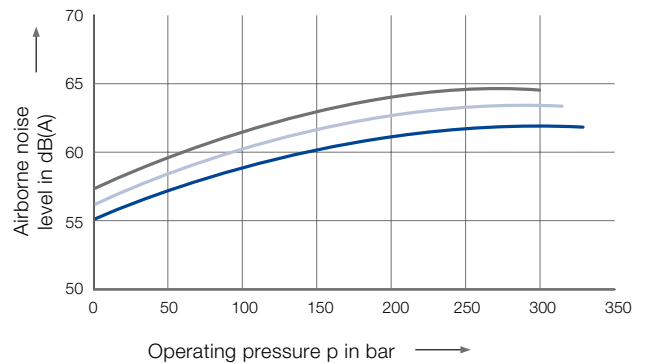
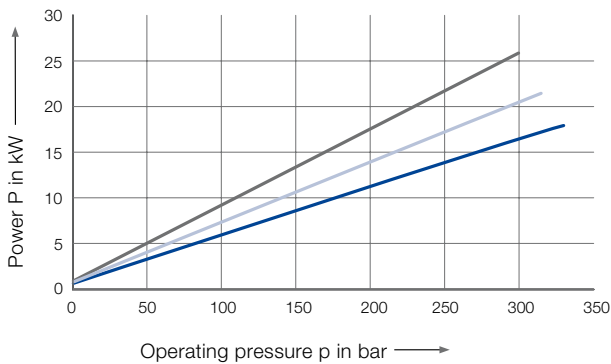

Characteristic curves:

— IPH 4 – 20    — IPH 4 – 25    — IPH 4 – 32

## IPH Standard design 5, Rotation and Dimensions

Clockwise rotation (cw)

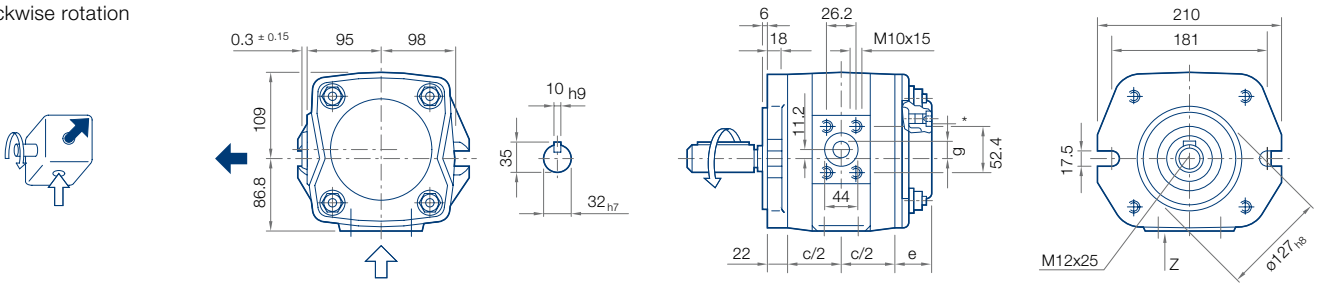

Counterclockwise rotation (ccw)

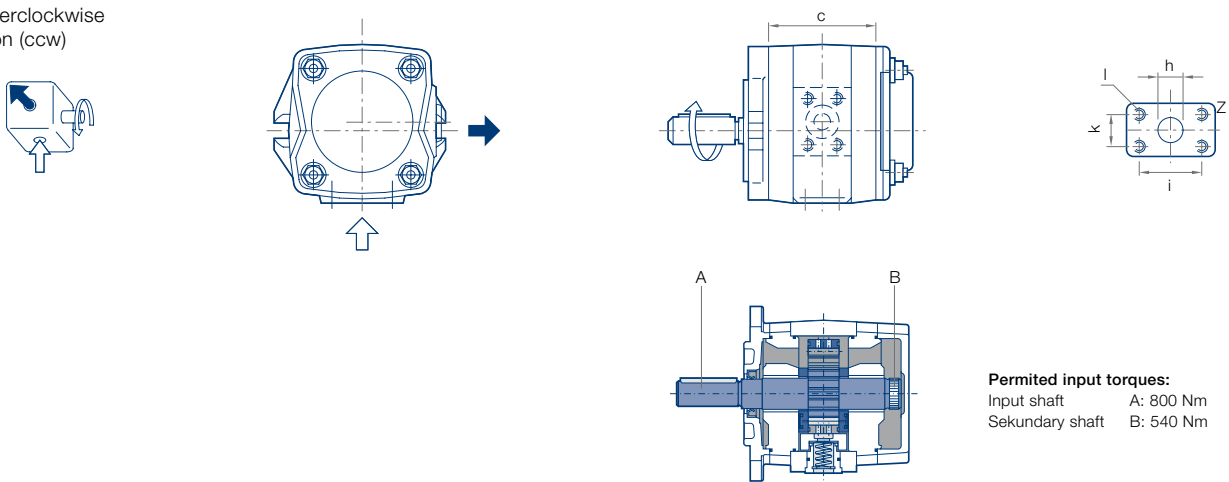

Permitted input torques:  
 Input shaft A: 800 Nm  
 Sekundary shaft B: 540 Nm

Type / Delivery	Dimensions and Weight								SAE-Flange-No.	
	c	e	g	h	i	k	l	m	↑	↓
	[mm]	[mm]	[mm]	[mm]	[mm]	[mm]	Thread	[kg]		
IPH 5 – 40	138	35	24	35	69.9	35.7	M12 x 19	26.8	12	30
IPH 5 – 50	145	35	27	42	69.9	35.7	M12 x 19	28.3	12	30
IPH 5 – 64	155	35	29	42	69.9	35.7	M12 x 19	30.0	12	30

\* The plug screw must be closed during operation. Ensure the M10x1 plug screw, hexagon socket SW5, is tightened to a torque of 10 Nm. Depending on the pump position, filling or ventilation is possible with the M10x1 plug screw prior to commissioning.

### Delivery Q

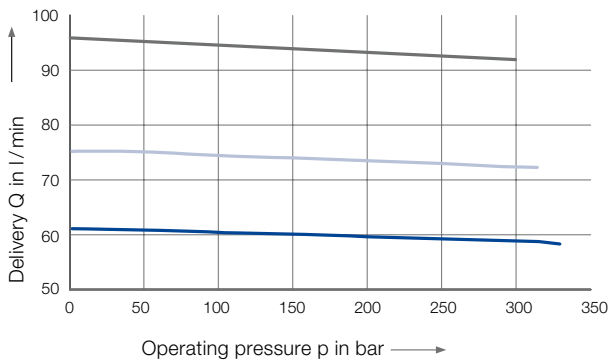

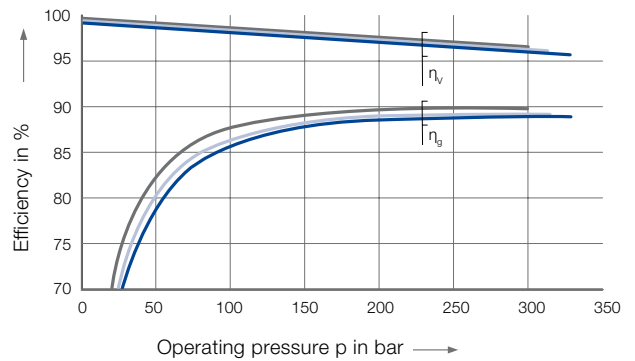

**Note:**  
 Measurement taken in a low-noise room.  
 In an anechoic room, the measurements are approx. 5 dB(A) lower.

### Efficiency $\eta_v$ and $\eta_g$

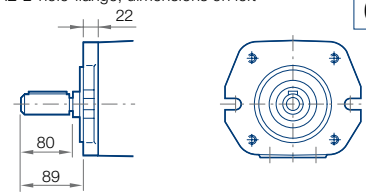
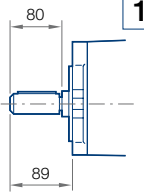

**Measurement conditions:**  
 Speed: 1500 min<sup>-1</sup> / Viscosity of pressure fluid: 46 mm<sup>2</sup>s<sup>-1</sup> /  
 Operating temperature: 40 °C

IPH standard design 5, Designs

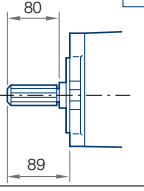
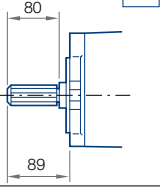
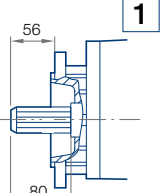
Type	Pump sizes	Rotation, suction connection	Mounting flange	Shaft end
IPH 5	40 50 64	Standard		
		Clockwise rotation, radial suction port <b>1</b> 	SAE-2-hole-flange, dimensions on left <b>0</b> 	Parallel shaft with keyway connection, dimensions on left <b>1</b> 
		Variants		
		Counterclockwise rotation, radial suction port <b>6</b> 		Involute gearing with SAE-2-hole-flange <b>0</b> ANSI B92.1a 14T 12/24 DP 30° 
			SAE-4-hole-flange <b>1</b> 	Involute gearing with SAE-4-hole-flange <b>1</b> ANSI B92.1a 14T 12/24 DP 30° 

Designation according to type code  
 Type code/order designation, see page 13

Input power P

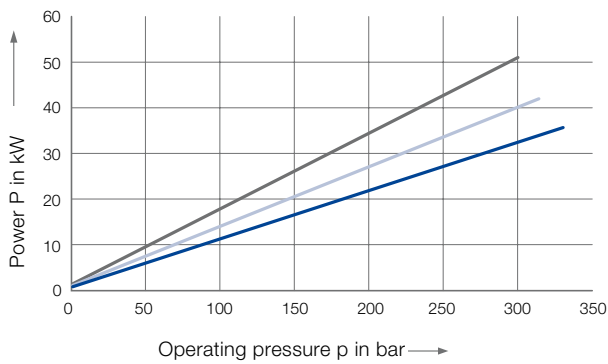

Characteristic curves:  
 — IPH 5 - 40    — IPH 5 - 50    — IPH 5 - 64

Airborne noise level (Measurement site 1 m axial)

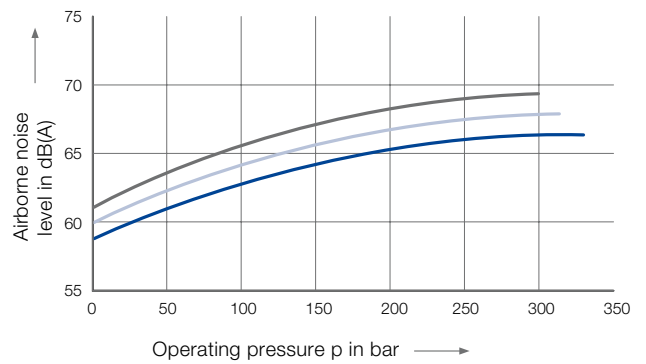

## IPH Standard design 6, Rotation and Dimensions

Clockwise rotation (cw)

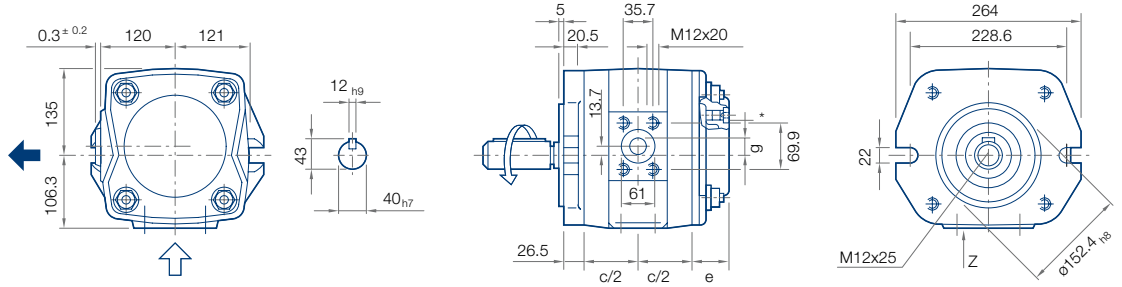
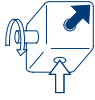

Counterclockwise rotation (ccw)

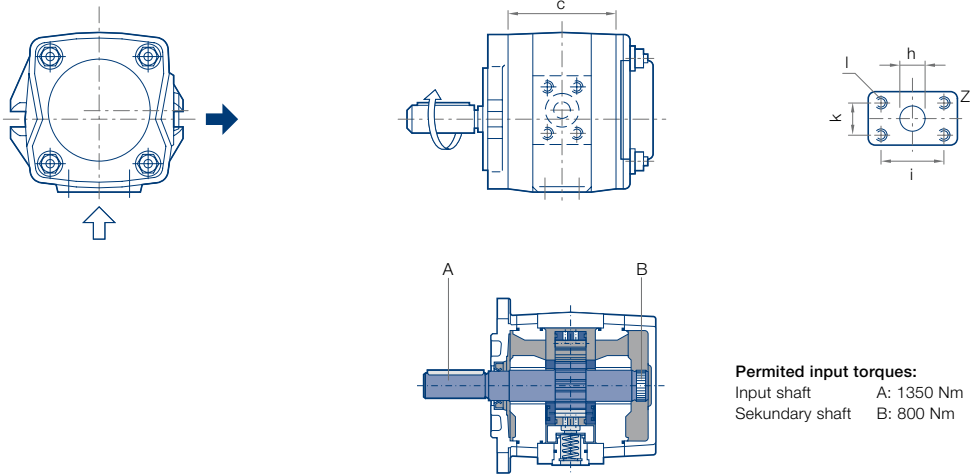

**Permitted input torques:**  
 Input shaft A: 1350 Nm  
 Sekundary shaft B: 800 Nm

Type / Delivery	Dimensions and Weight								SAE-Flange-No.	
	c	e	g	h	i	k	l	m	↑	↓
	[mm]	[mm]	[mm]	[mm]	[mm]	[mm]	Thread	[kg]		
IPH 6 – 80	171	49	32.5	50	77.8	42.9	M12 x 23	50.5	14	15
IPH 6 – 100	181	49	36	50	77.8	42.9	M12 x 23	54	14	15
IPH 6 – 125	193	47	39	50	77.8	42.9	M12 x 23	58	14	15

\* The plug screw must be closed during operation. Ensure the M10x1 plug screw, hexagon socket SW5, is tightened to a torque of 10 Nm. Depending on the pump position, filling or ventilation is possible with the M10x1 plug screw prior to commissioning.

### Delivery Q

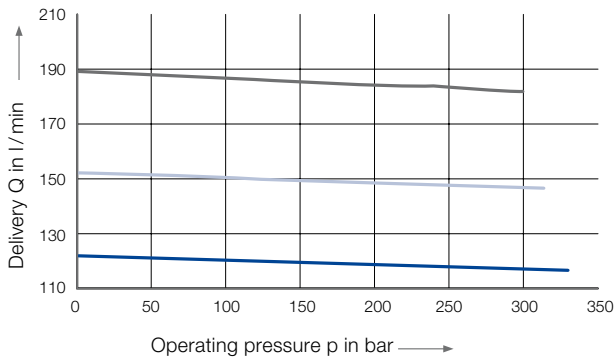

**Note:**  
 Measurement taken in a low-noise room.  
 In an anechoic room, the measurements are approx. 5 dB(A) lower.

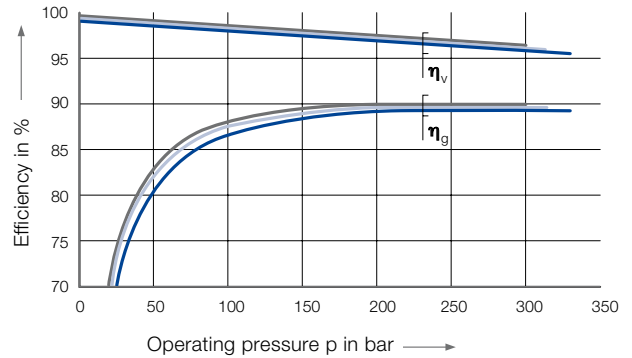

### Efficiency $\eta_v$ and $\eta_g$



**Measurement conditions:**  
 Speed: 1500 min<sup>-1</sup> / Viscosity of pressure fluid: 46 mm<sup>2</sup>s<sup>-1</sup> /  
 Operating temperature: 40 °C

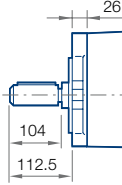
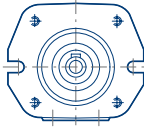

IPH standard design 6, Designs

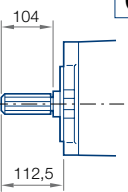
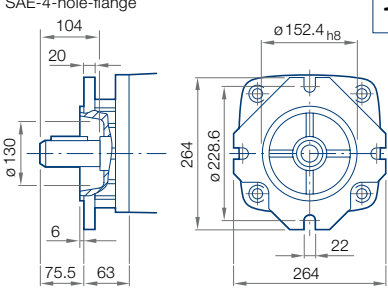
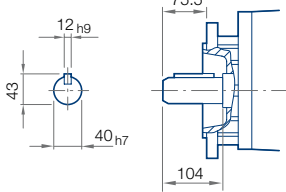
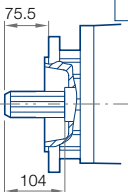
Type	Pump sizes	Rotation, suction connection	Mounting flange	Shaft end
IPH 6	80 100 125	Standard		
		Clockwise rotation, radial suction port <b>1</b>	SAE-2-hole-flange, dimensions on left <b>0</b>	Parallel shaft with keyway connection, dimensions on left <b>1</b>
				
Variants				
		Counterclockwise rotation, radial suction port <b>6</b>		Involute gearing with SAE-2-hole-flange <b>0</b>
				
			SAE-4-hole-flange <b>1</b>	Involute gearing with SAE-4-hole-flange <b>1</b>
				
				Involute gearing with SAE-4-hole-flange <b>1</b>
				

 Designation according to type code  
Type code/order designation, see page 13

Input power P

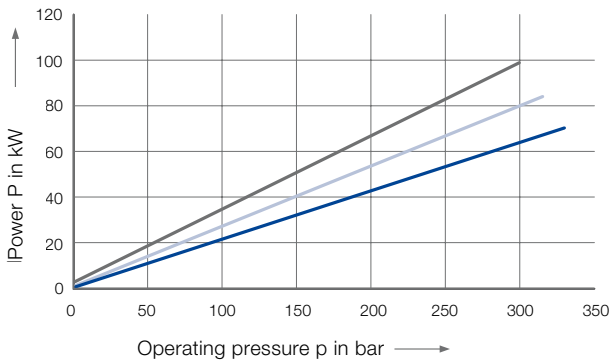

Airborne noise level (Measurement site 1 m axial)

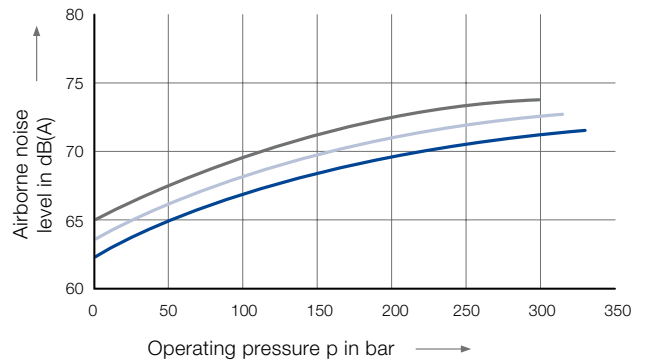

Characteristic curves:

 IPH 6 - 80     IPH 6 - 100     IPH 6 - 125

## Suction and pressure flanges SAE J 518 C code 61, single-piece

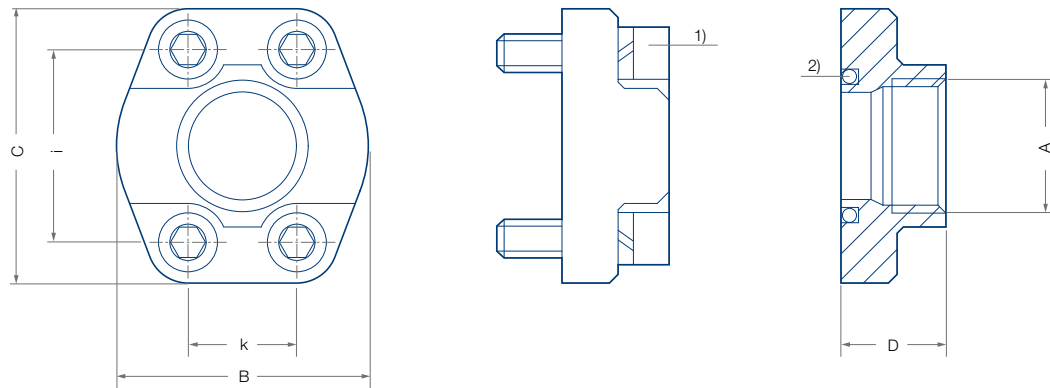

### Wrench torque for screws according to ISO 6162

<sup>1)</sup> Round seal ring (O-ring) ISO-R 1629 NBR

<sup>2)</sup> Machine screw EN ISO 4762

<sup>3)</sup> Special design, deviating from SAE J 518 C code 61

SAE-flange-No.	A	B	C	D	E <sup>1)</sup>	i	k	S <sup>2)</sup>	max. pressure
	Thread	[mm]	[mm]	[mm]	Seal ring	[mm]	[mm]	Thread	[bar]
10	G ½	46	54	36	18.66 – 3.53	38.1	17.5	M 8	345
11	G ¾	50	65	36	24.99 – 3.53	47.6	22.3	M 10	345
12	G 1	55	70	38	32.92 – 3.53	52.4	26.2	M 10	345
13	G 1-¼	68	79	41	37.69 – 3.53	58.7	30.2	M 10	276
14 <sup>3)</sup>	G 1-½	82	98	50	47.22 – 3.53	69.9	35.7	M 12	345 <sup>3)</sup>
30	G 1-½	78	93	45	47.22 – 3.53	69.9	35.7	M 12	207
15	G 2	90	102	45	56.74 – 3.53	77.8	42.9	M 12	207
16	G 2-½	105	114	50	69.44 – 3.53	88.9	50.8	M 12	172
17	G 3	124	134	50	85.32 – 3.53	106.4	61.9	M 16	138
18	G 4	146	162	48	110.72 – 3.53	130.2	77.8	M 16	34

## Multi-flow pumps, pump combinations, pump combinations in order of type and size

---

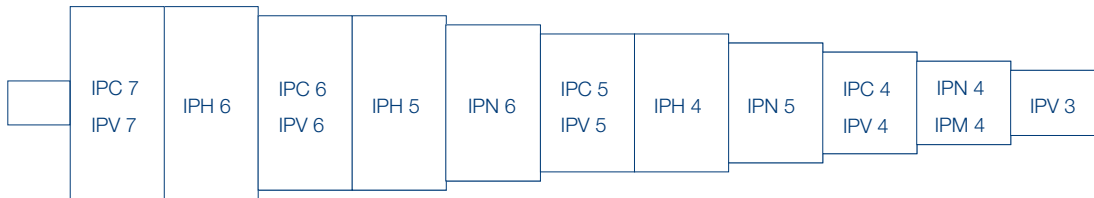

### Combinations of IPC pumps

---

- IPC pumps of identical or different sizes can be combined to form multi-flow pumps.
- All sizes with each displacement
- are available as two or three-flow pumps; four-flow pumps must be designed by Voith.
- The pumps are arranged in increasing order according to size and delivery.

### Combination of IPC/IP... pumps

---

- It is possible to combine IPC pumps with other Voith pump series (e.g. high-pressure pumps IPV or low-pressure pumps IPN).
- The pumps are arranged by type and size, as shown in the illustration above.
- If identical types or identical sizes follow each other, the pump with the higher pump flow is placed closer to the drive.

### Selection

---















1. Identify the pressure ranges and then choose the appropriate pump series.
2. Identify the deliveries, and then select the appropriate size(s).
3. Define the sequence of the pumps.
4. Check the torque.
5. Determine the direction of rotation and suction.
6. Specify the mounting flange and shaft end.

### Connection, assembly

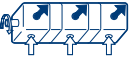
---

- As a rule, multi-flow pumps are mounted to the drive using a flange. All information on flange designs and shaft ends is contained in the relevant pump series catalog.
- For further relevant information, such as how to determine the adapter housing, see brochure No. G 1714 (Voith Multi-Flow Pumps).

## Designs

Rotation and suctions			Mounting flange			Shaft end		
clockwise (cw)   counterclockwise (ccw)								
	1	6						
	1	6		0	1	1	1	0
	3	8						
	3	8		For designs and dimensions, see catalog for the relevant pump series.		For designs and dimensions, see catalog for the relevant pump series.		
Special design	4	9	Special design	0	SAE-2-hole-flange			
				1	SAE-4-hole-flange			



This is a translated document. Original language: german.  
Legally binding language version of document: german.

