

APPLICATION

The 4064 Accelerometer is used primarily with Vitec monitoring systems. It has an unamplified, charge output that limits cable run distances to 100 ft or less, and can be used in applications to 550 °F.

INSTALLATION, ELECTRICAL

Cable Type: Use high quality, twisted, shielded cable between the transducer terminals and monitor terminals. Use of Vitec supplied cable assemblies is recommended.

Cable Length: Transducer to monitor cable length should not exceed 100 ft.

Cable Splicing: If cable splices are made, complete shielding must be maintained.

Cable Routing: Proper cable routing is required to avoid false signals being introduced into the measuring device (monitor). Avoid running accelerometer wires adjacent to, or parallel to, AC power lines. Where possible, provide a separate, grounded conduit to enclose the accelerometer cable. Route cable away from radio transmission equipment, motors, generators, and transformers. Avoid running cable through areas prone to ESD (Electro Static Discharge) or EMI (Electromagnetic Interference).

Cable Grounding: Connect the cable shield to a good, earth ground connection, at one end only (preferably at the monitor end of the cable). Vitec monitors provide this connection as a terminal block connection point.

Cable Anchoring: Cable should be clamped at regular intervals to keep it from twisting or flexing. Cable motion will induce electrical noise into the monitoring system, causing inaccurate readings.

INSTALLATION, MECHANICAL

Location: Mount on, or as close as possible to, the bearing being monitored. Preferable mounting location is on the bearing cap.

Direction: The accelerometer is only sensitive to vibrations that are occurring in the direction of the transducer's axis (the imaginary line running through the center of the connector and the mounting stud). Therefore, mount the transducer in a direction that will sense the vibrations to be measured.

Surface Preparation: The mounting surface must be flat and smooth. For best results, mounting surface should be flat to within 0.001 in TIR (Total Indicated Runout) over the full base dimension of the transducer, with a minimum 63 µin finish.

Stud Mounting: If stud mounting is used, drill and tap the mounting point for a 1/4-28 UNF stud, with a minimum thread depth of 3/8 in.

Square Base Mounting: If the four hole mounting base is used, drill and tap the mounting point for four, No. 6-32 UNF screws, with a minimum thread depth of 1/4 in.

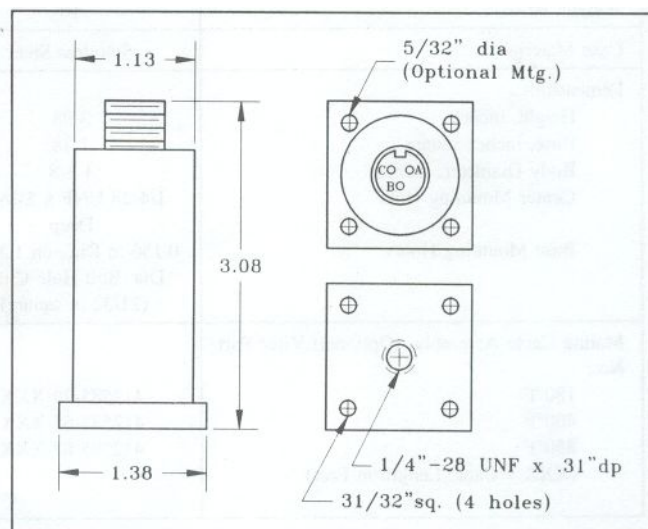

SPECIFICATIONS

Dynamic:	
Output, pico-coloumbs/G, +/- 5%	1,050
Frequency Response, Hz, +/- 5%	1 to 600
Dynamic Range, Gs	0.001 to 500.0
First Mounted Resonant Frequency, KHz	5 - 7
Transverse Axis Sensitivity, % max., 50 to 800 Hz	5
Temperature Sensitivity, % change in output, -100 to 550°F	+/- 10
Linearity, % over dynamic range	+/- 3

Electrical:	
Power Requirements	None, Self Generating
Internal Capacitance, μ f, +/- 20%	0.012
Grounding, Sensing Element	Internally Ungrounded and Shielded
Connections (Connector): Pin A Pin B Pin C	Signal Shield Signal Return
Element Isolation from Case, dB min. at 60 Hz	60

Environmental:	
Temperature Range, °F	-100 to 550

Physical:	
Vitec Part No.:	602885-46RR
Weight, oz.	10
Case Material	Stainless Steel
Dimensions: Height, inches Base, inches square Body Diameter, inches Center Mounting Hole Base Mounting Holes	3.08 1.38 1 1/8 1/4-28 UNF x 5/16 in Deep 0.156 in Dia., on 1.38 in Dia. Bolt Hole Circle (21/32 in square).
Mating Cable Assembly, (Optional) Vitec Part No.:	
180°F	412585-79-XXX
400°F	412585-65-XXX
850°F	412585-87-XXX
(XXX = Cable Length in Feet)	

Vitec, Inc.
 24755 Highpoint Rd.
 Cleveland, OH 44122
 Phone: 216-464-4670
 Fax: 216-464-5324