

DKZ 110 H ZWISCHENFLANSCHKLAPPE

BUTTERFLY VALVE

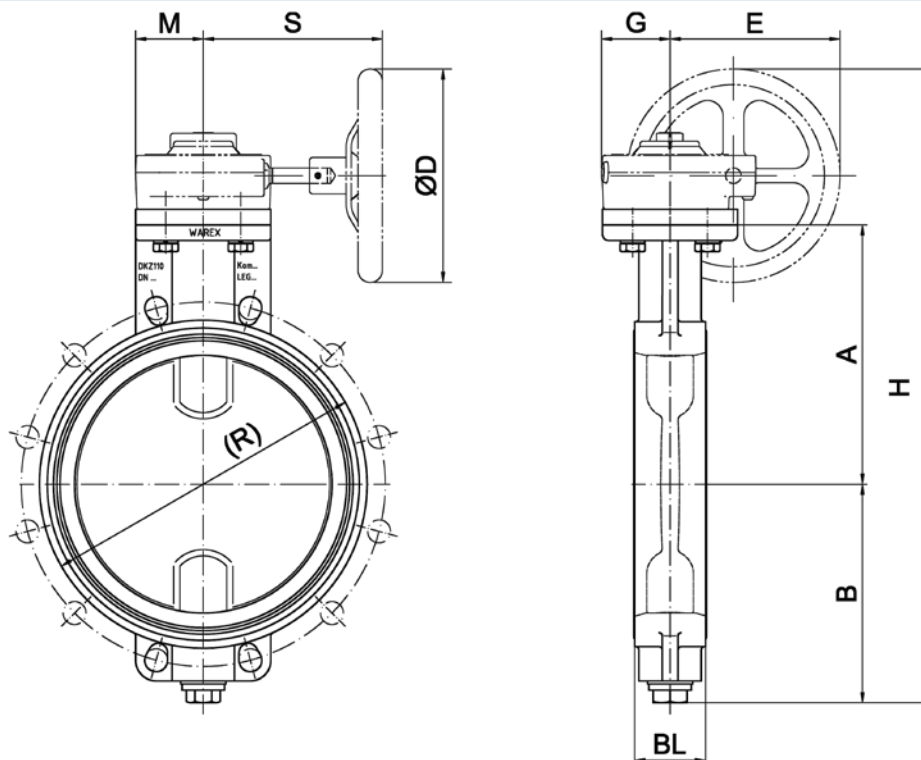

DKZ 110 H Zwischenflanschklappe / Butterfly Valve

DN	A	B	(R)	BL	Getriebe gear	M	S	G	E	Ø D	(H)
50	110	70	98	39	9801/SR5	57	153	57	102	125	311
65	118	78	118	39	9801/SR5	57	153	57	102	125	327
80	125	85	134	39	9801/SR5	57	153	57	102	125	341
100	135	97	154	39	9801/SR5	57	153	57	102	125	363
125	163	123	183	44	9801/SR8	57	160	57	139	200	469
150	175	136	209	44	9801/SR8	57	160	57	139	200	495
200	200	161	263	54	9801/SR8	57	160	57	139	200	545
250	249	208	312	68	9804/SR8	65	170	66	152	200	605
300	274	232	372	78	9804/SR8	65	170	66	152	200	654
350	305	280	425	67	9807/SR12	82	223	82	218	300	788
400	329	303	473	67	9807/SR12	82	223	82	218	300	835
450	400	337	539	102	9807/SR12	82	223	82	218	300	940
500	404	368	581	77	M14/R14	99	247	86	265	350	1012
600	454	417	680	77	M14/R18	99	279	86	318	457	1165

Hinweis: Flanschmaße finden sie in den Technischen Daten /
For flange dimensions please see technical data
() = Abweichungen möglich / May vary

Getriebeauslegung je nach Einsatzbedingungen abweichend /
Driving selection according to different operating conditions

We reserve all rights and changes
Technische und maßliche Änderungen vorbehalten